

EXPERT

www.SheepShearingEquipment.com.au

COMB PENDULUM

Part # 511-002
Patent Pending

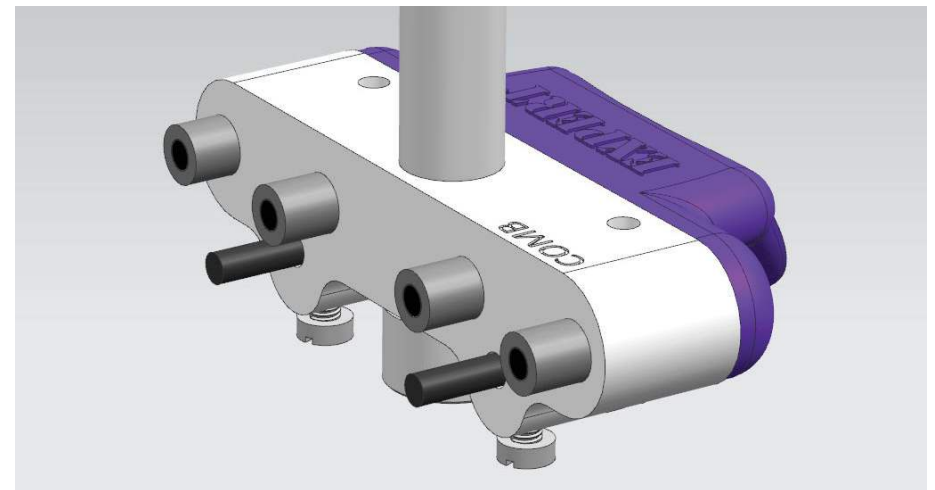

| | | |
|------|-----------------|---------------------------|
| 15 | 511026 | MAGNET |
| 14 | 511025 | SWIVEL SCREW |
| 13 | 511024 | HANGING TUBE BOLT |
| 12 | 511023 | HANGING TUBE COLLET |
| 11 | 511022 | HANGING TUBE NUT |
| 10 | 511021 | HANGING SWIVEL |
| 09 | 511020 | HANGING ROD |
| 08 | 511019 | HANGING TUBE |
| 07 | 511018 | LOCATING PIN SCREW |
| 06 | 511017 | LOCATING PIN |
| 05 | 511016 | ROCKER SPRING PIN |
| 04 | 511015 | ROCKER |
| 03 | 511014 | PUSHER PIN |
| 02 | 511013 | THUMB GRIP |
| 01 | 511011 / 511012 | CUTTER BLOCK / COMB BLOCK |
| ITEM | PART NUMBER | DESCRIPTION |

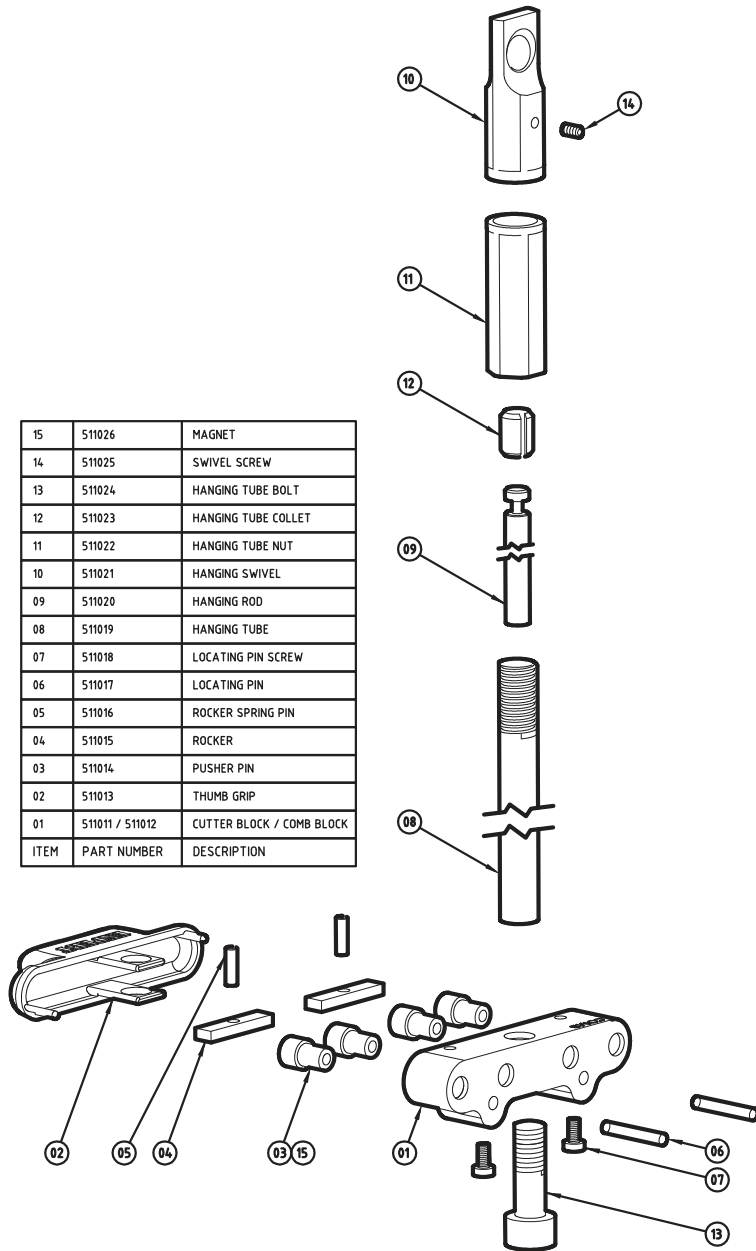

EXPERT SHEARING EQUIPMENT

8 SHOLL STREET MANDURAH 6210
WESTERN AUSTRALIA

EMAIL: EXPERT@SheepShearingEquipment.COM.AU

Operating Instructions

- 1) Draw a line through the middle of your grinding disc and attach the disc to the Grinder. **(Diagram 1)**
- 2) Draw a line through the middle of your comb. **(Diagram 2)**
- 3) With the drawn-on comb on the locating pins hang the pendulum from the grinder and adjust the pendulum length until the line through the comb and disc line up with the comb 5mm in from the side of the disc. Tighten the hanging tube nut. **(Diagram 3a and 3b)**
- 4) With a comb on the pendulum hang it from the grinder hook. Adjust the grinder hook in or out until the heel (bottom) of the comb hits the grinder disc and the tips (top) of the comb is a match thickness (2mm) off the grinder disc. Tighten the grinder hook adjusting nut on the grinder. You are now ready to grind. **(Diagram 4)**
- 5) Grind by landing your comb on the disc moving towards the nut, take it to the centre of the disc and then to the very outside of the disc taking 2 to 3 teeth off the edge of the disc. On the last stroke move from the inside of the disc to the position where you set the length of the pendulum (3 above) and snap it off the disc.
- 6) Check in a good light, check all cutting edges where the tip of the cutter would have rubbed are sharp. Look for rounded edges if they appear resharpen.

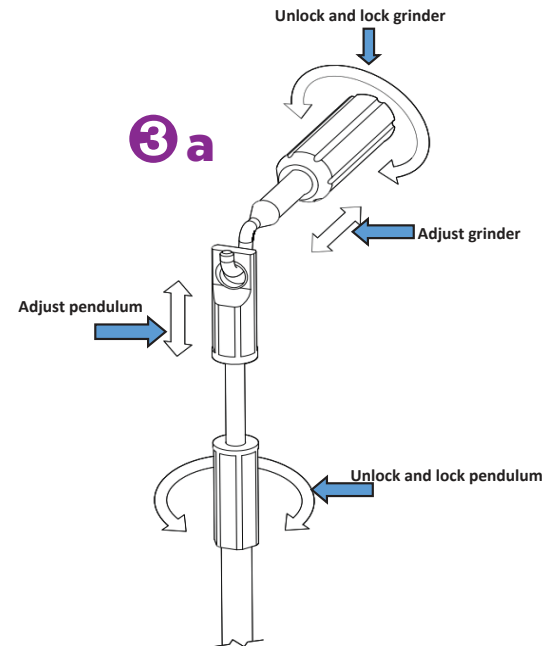
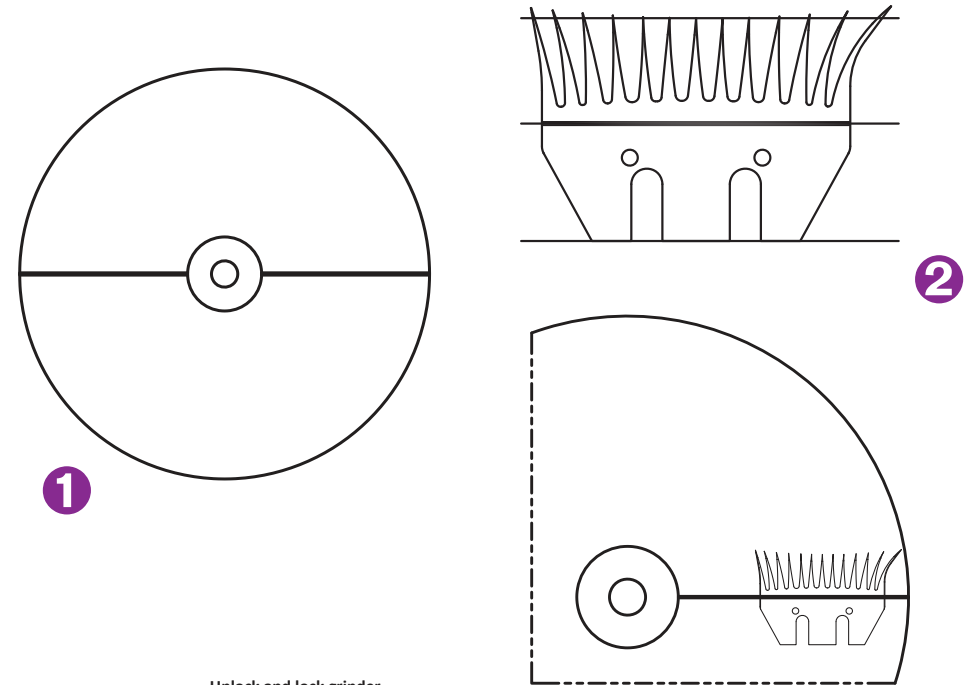

3b

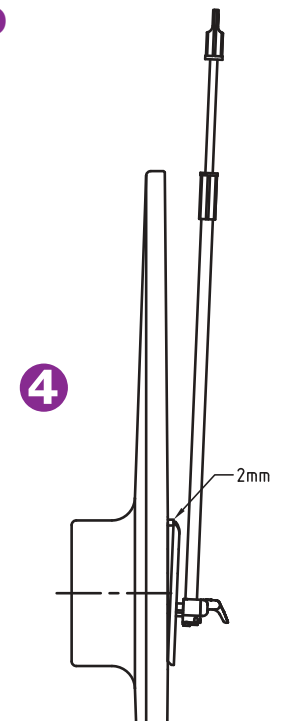

4

Safety Instructions

- Always wear eye protection
- Always wear ear protection
- Always press directly inwards towards the disc
- Keep small children clear of work area

Care and Repair

- Wipe excess grinding dust from magnets
- Never use air pressure to clean the magnets
- Never oil or lubricate the pendulum
- All parts are available from your distributor