

# EXPERT

[www.SheepShearingEquipment.com.au](http://www.SheepShearingEquipment.com.au)

## CUTTER PENDULUM

Part # 511-001  
Patent Pending

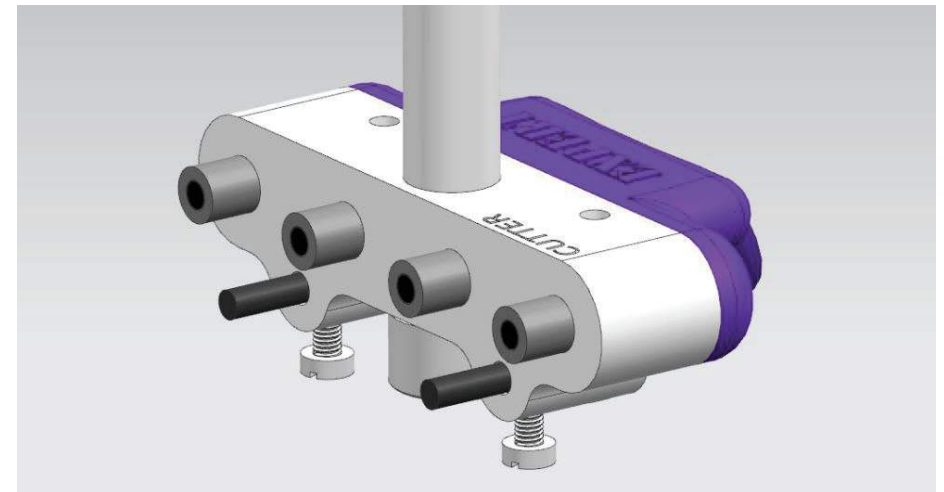

ITEM	PART NUMBER	DESCRIPTION
15	511026	MAGNET
14	511025	SWIVEL SCREW
13	511024	HANGING TUBE BOLT
12	511023	HANGING TUBE COLLET
11	511022	HANGING TUBE NUT
10	511021	HANGING SWIVEL
09	511020	HANGING ROD
08	511019	HANGING TUBE
07	511018	LOCATING PIN SCREW
06	511017	LOCATING PIN
05	511016	ROCKER SPRING PIN
04	511015	ROCKER
03	511014	PUSHER PIN
02	511013	THUMB GRIP
01	511011 / 511012	CUTTER BLOCK / COMB BLOCK

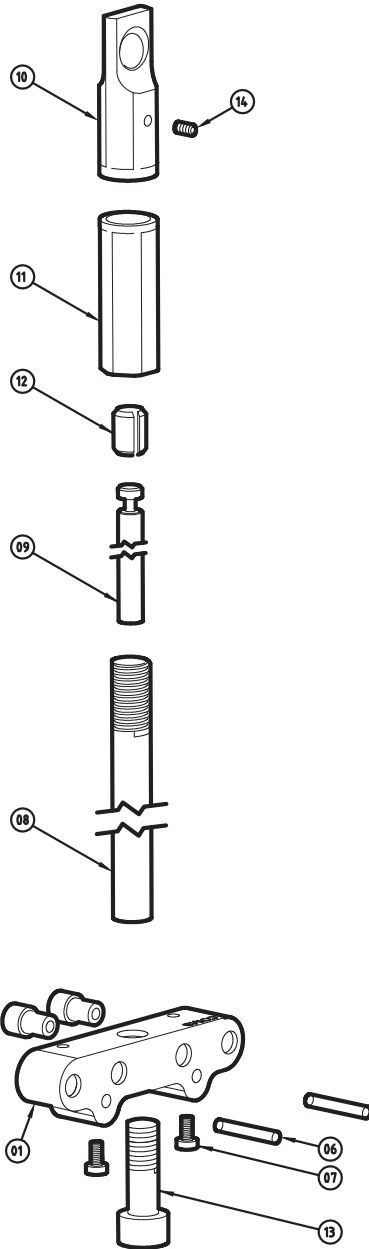

### EXPERT SHEARING EQUIPMENT

8 SHOLL STREET MANDURAH 6210

WESTERN AUSTRALIA

TEL +61 (0) 0411 265 369

EMAIL: [EXPERT@SHEEPSHEARINGEQUIPMENT.COM.AU](mailto:EXPERT@SHEEPSHEARINGEQUIPMENT.COM.AU)

## Operating Instructions

- 1) Draw a line through the middle of your grinding disc and attach the disc to the Grinder. **(Diagram 1)**
- 2) Draw a line through the middle of your cutter. **(Diagram 2)**
- 3) With the drawn-on cutter on the locating pins hang the pendulum from the grinder and adjust the pendulum length until the line through the cutter and disc line up with the cutter 25mm in from the side of the disc. Tighten the hanging tube nut. **(Diagram 3a and 3b)**
- 4) With a cutter on the pendulum hang it from the grinder hook. Adjust the grinder hook in or out until the cutter sits flat on the grinder disc as it touches the discs. Tighten the grinder hook adjusting nut on the grinder. You are now ready to grind. **(Diagram 3a and 4)**
- 5) Grind by landing your cutter on the disc moving towards the nut, take it to the centre of the disc and then to the very outside of the disc, ensure you use all of the emery. On the last stroke move from the inside of the disc to the position where you set the length of the pendulum and snap it off the disc.
- 6) Check in a good light check all cutting edges around the tips of all teeth are sharp. Look for rounded edges if they appear resharpen.

### Safety Instructions

- Always wear eye protection
- Always wear ear protection
- Always press directly inwards towards the disc
- Keep small children clear of work area

### Care and Repair

- Wipe excess grinding dust from magnets
- Never use air pressure to clean the magnets
- Never oil or lubricate the pendulum
- All parts are available from your distributor

